



STAR Drain

DRAINAGE CHANNEL SYSTEMS

Innovation and expertise in
drainage technology



www.pck-belgium.com



PCK Belgium is a company established in Belgium. It was started in June 2012, but it has gained expertise during a period of forty years in relation to drainage technology.

Our sales office in Vancouver (Canada) was opened in May 2018 to access the North American market.

Our products, the stylish Star Drain and Aqua Drain series, are currently being produced in three dimensions for all your drainage requirements. All products that we have developed are of a high quality and are processed using the most modern of technologies.

In 2023, we also decided to expand our range to more design and to do so in stainless steel. We have also added a new black, Premium Black. This black has a rougher edge but is still very attractive to install as line drainage.

PCK Belgium knows it supplies quality products that will withstand the ravages of time thanks to its choice of raw materials: PVC and aluminium.

PCK Belgium has the facilities that allow it to consolidate deliveries with different products, which guarantees that customers have a greater degree of flexibility in relation to stock.

A handwritten signature in blue ink, appearing to read 'Peter Schelstraete', is written over a light blue, wavy background.

Peter Schelstraete, 2021



TECHNICAL SPECIFICATIONS / MATERIALS

Description:

STAR-Drain is a simple and discreet drainage channel system with drainage elements in high quality extruded PVC. The channels are easy to install - even for self-builders. The elements comes in lengths of 1000 mm, made easy to assemble with practical connection pieces, that are glued and clicked onto the channels from below. The channel elements can also be easily shortened to suitable lengths by using a hacksaw or an angle grinder

The channels are mounted with inserted top gratings of either black or natural gray aluminum, or corten steel. The gratings stabilizes the channels and creates a nice transition from the channel to the surrounding pavement.

STAR-Drain is available in channel widths and heights of 60 X 60 mm, 65x100 mm, 100x50 mm, and 100 x 100 mm.

A full range of accessories is available for the STAR-Drain channel system. Connectors, end pieces, corner elements and T-elements. Channel drains are established either from the bottom of the channel, with a vertical outlet, or through th end piece with a horizontal outlet. STAR-Drain is classified for load class A15 (1,5 tons). For light traffic areas, exclusively used by pedestrians, cyclists and the like.

Base element :

Extruded PVC-profile

Gratings :

Aluminium steel :

Anodized aluminium profile
Nature gray or black coating.

Corten steel

Stainless steel

Materials :

EN AW-6060 T66 / A 588 CORTEN
EN 573-3
NEN-ISO 10074
PVC (polyvinylchlorid)

Dimension or weight :

Please look up listed data in table inside the brochure

Load Class :

15 kN (A15) - when installed in accordance with installation instructions (page 10-11)

Approval standard :

BS EN1433.2002

ACCESSORIES



Corner unit
aluminium gray



Corner unit
aluminium black



Corner unit
cortensteel



Closing end cap

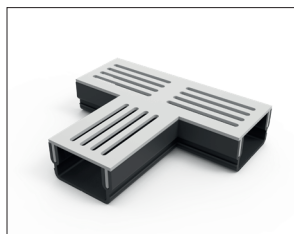

T- unit
aluminium gray



T- unit
aluminium black

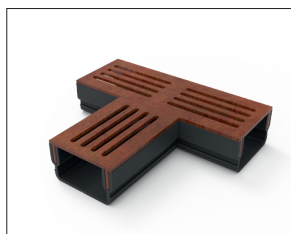

T- unit cortensteel

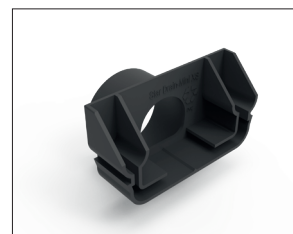

End cap with Ø 30mm
outlet

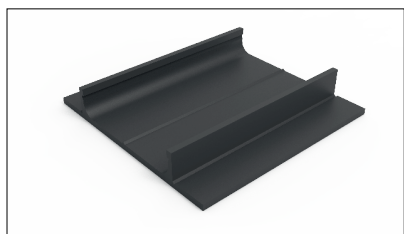

Channel connector

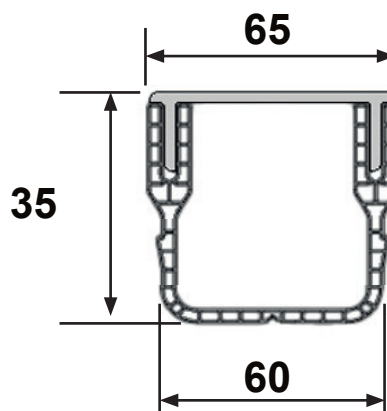

Maximum flow rate : 180 l/min.



NEW !

STAR Drain "MINI" XS

65 x 35 mm



Product line-up

N° art.	Description	Width mm	Height mm	Lenght mm	Load Class	Weight kg
Channel elements (with grating)						
300-2025	STAR-Drain MINI XS channel 1m, 65x35 mm. with gray aluminum grating	65	35	1000	A15	1,400
301-2025	STAR-Drain MINI XS channel 1m, 65x35 mm. with black aluminum grating	65	35	1000	A15	1,400
302-2025	STAR-Drain MINI XS channel 1m, 65x35 mm. with Corten steel grating	65	35	1000	A15	2,440
Accessories (incl. gratings)						
312-2025	Star Drain MINI XS - corner unit with gray aluminium grating for 65 x 35	65	35	197 / 197	A15	0,580
313-2025	Star Drain MINI XS -T-unit with gray aluminium grating for 65 x 35	65	35	196 / 272	A15	0,725
314-2025	Star Drain MINI XS - corner unit with black aluminium grating for 65 x 35	65	35	197 / 197	A15	0,580
320-2025	Star Drain MINI XS - T-unit with black aluminium grating for 65 x 35	65	35	196 / 272	A15	0,725
321-2025	Star Drain MINI XS - corner unit with Corten steel grating for 65 x 35	65	35	197 / 197	A15	0,900
322-2025	Star Drain MINI XS - T-unit with Corten Steel grating for 65 x 35	65	35	196 / 272	A15	1,200
Accessories (excl. gratings)						
308-2025	Star Drain MINI XS, channel connector for 65 x 35	65	35	135	A15	0,105
309-2025	Star Drain MINI XS, channel connector with vertical outlet for 65 x 35	65	35	135	A15	0,125
310-2025	Star Drain MINI XS, end cap closed for 65 x 35	65	35		A15	0,037
311-2025	Star Drain MINI XS, end cap with horizontal outlet for 65 x 35	65	35		A15	0,045

STAR Drain Mini XS Stainless steel Line 65 x 35 mm

NEW !

ACCESSORIES



**Falcon Line Mini
corner unit**



**Viking Line Mini
corner unit**



**Falcon Line Mini
T-unit**



**Viking Line Mini
T-unit**



**Diamond Line Mini
corner unit**



**Premium Black Line
Mini corner unit**



**Diamond Line Mini
T-unit**



**Premium Black Line
Mini T-unit**



**Inox Line Mini
corner unit**

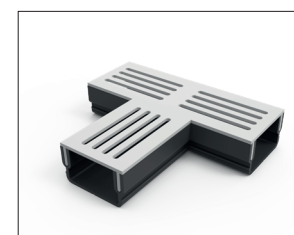

**Inox Line Mini
T-unit**

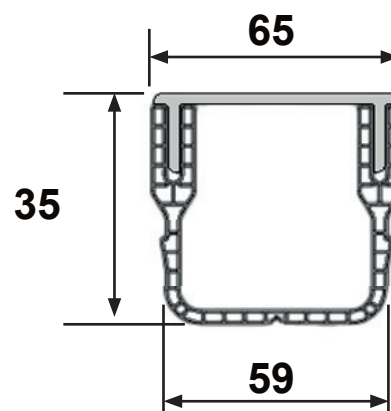

Maximum flow rate : 180 l/min.



Star Drain Mini XS Stainless steel

NEW !

65 x 35 mm

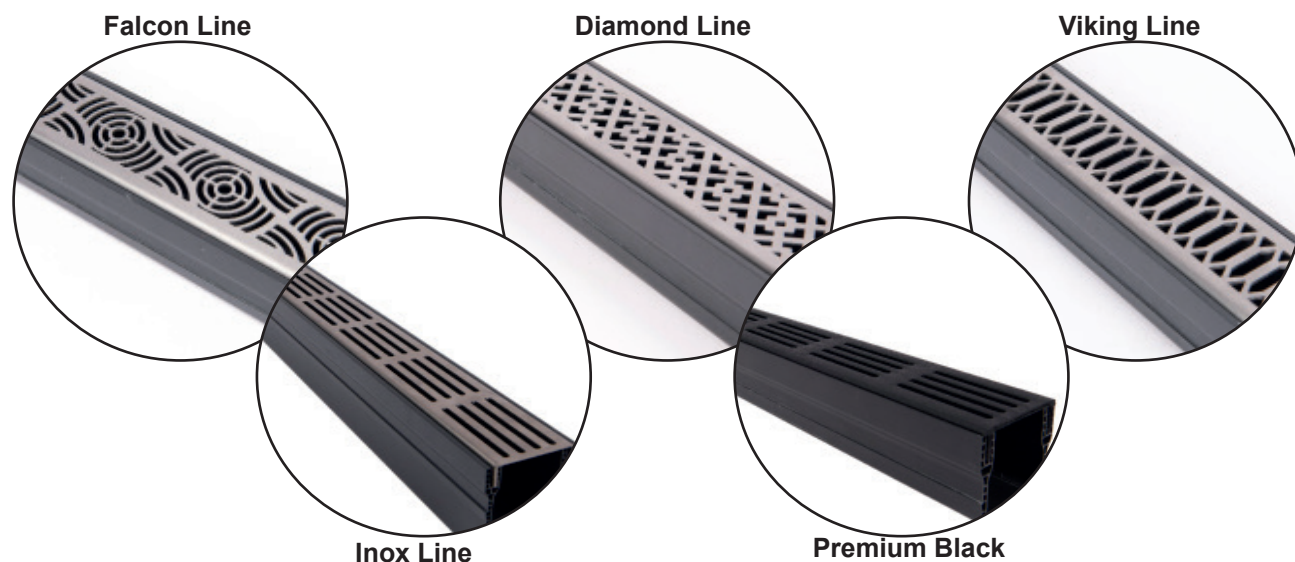

N° art.	Description	Width mm	Height mm	Lenght mm	Load Class	Weight kg
Channel elements (with grating)						
303-2025	Falcon Line-channel MINI XS 1 m, 65 x 35 mm with grey stainless steel grating	65	35	1000	A15	2,000
304-2025	Viking Line-channel MINI XS 1 m, 65 x 35 mm with grey stainless steel grating	65	35	1000	A15	1,960
305-2025	Diamond Line-channel MINI XS 1 m, 65 x 35 mm with grey stainless steel grating	65	35	1000	A15	2,000
306-2025	Premium Black Line-channel MINI XS 1 m, 65 x 35 mm with black aluminium grating	65	35	1000	A15	1,400
307-2025	Inox Line-channel MINI XS 1 m, 65 x 35 mm with grey stainless steel grating	65	35	1000	A15	1,960
Accessories (with grating)						
315-2025	Falcon Line-MINI XS corner unit with grey stainless steel grating for 65 x 35	65	35	149/149	A15	0,260
316-2025	Viking Line-MINI XS corner unit with grey stainless steel grating for 65 x 35	65	35	149/149	A15	0,260
317-2025	Diamond Line-MINI XS corner unit with grey stainless steel grating for 65 x 35	65	35	149/149	A15	0,260
318-2025	Premium Black Line-MINI XS corner unit with black aluminium grating for 65 x 35	65	35	149/149	A15	0,260
319-2025	Inox Line-MINI XS corner unit with grey stainless steel grating for 65 x 35	65	35	149/149	A15	0,260
323-2025	Falcon Line-MINI XS T unit with grey stainless steel grating for 65 x 35	65	35	156/182	A15	0,180
324-2025	Viking Line-MINI XS T unit with grey stainless steel grating for 65 x 35	65	35	156/182	A15	0,180
325-2025	Diamond Line-MINI XS T unit with grey stainless steel grating for 65 x 35	65	35	156/182	A15	0,180
326-2025	Premium Black Line-MINI XS T-unit with black aluminium grating for 65 x 35	65	35	156/182	A15	0,180
327-2025	Inox Line-MINI XS corner unit with grey stainless steel grating for 65 x 35	65	35	156/182	A15	0,180

STAR Drain "mini" 65 x 60 mm

ACCESSORIES



Corner unit
aluminium gray



Corner unit
aluminium black



Corner unit
corten steel



Closing end cap



T- unit
aluminium gray



T- unit
aluminium black



T- unit
corten steel

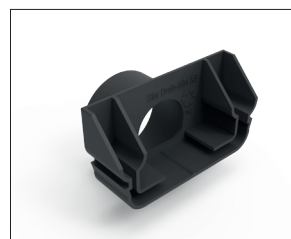

End cap with
Ø 40 mm outlet

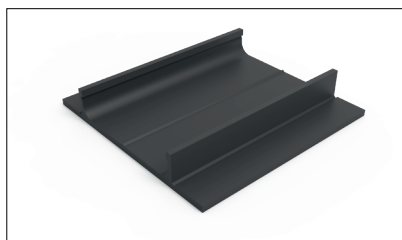

Channel connector

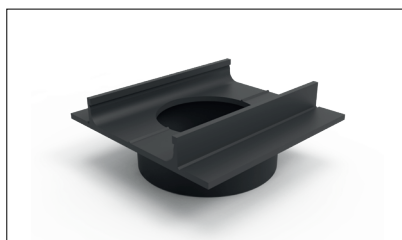

Channel connector with
Ø 75 mm vertical outlet

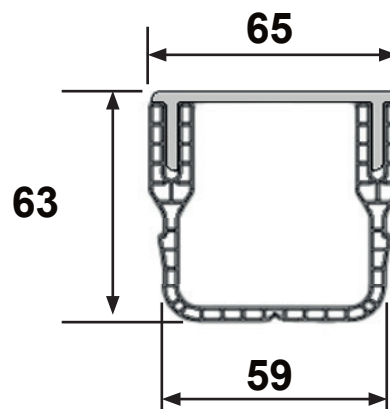

Maximum flow rate : 180 l/min.



STAR Drain « mini »

65 x 60 mm



Product line-up

N° art.	Description	Width mm	Height mm	Length mm	Load class	Weight kg
Channel elements (incl. gratings)						
150-2021	STAR-Drain MINI channel 1m, 65x60 mm. with gray aluminum grating	65	63	1000	A15	1,300
151-2021	STAR-Drain MINI channel 1m, 65x60 mm. with black aluminum grating	65	63	1000	A15	1,300
152-2021	STAR-Drain MINI channel 1m, 65x60 mm. with corten steel grating	65	63	1000	A15	2,400
Accessories (incl. gratings)						
157-2021	STAR-Drain MINI corner unit with gray aluminum grating, 65x60 mm	65	63	149 / 149	A15	0,380
160-2021	STAR-Drain MINI T unit with gray aluminum grating, for 65x100	65	63	156 / 182	A15	0,450
158-2021	STAR-Drain MINI corner unit with black aluminum grating, for 65x60	65	63	149 / 149	A15	0,380
161-2021	STAR-Drain MINI, T-unit with black aluminum grating, for 65x60	65	63	156 / 182	A15	0,450
159-2021	STAR-Drain MINI corner unit with corten steel grating, for 65x100	65	63	149 / 149	A15	0,630
162-2021	STAR-Drain MINI T-unit with corten steel grating, for 65x60	65	63	156 / 182	A15	0,730
Accessories (excl. gratings)						
153-2021	STAR-Drain MINI, Channel connector for 65x60	65	63	100	A15	0,071
154-2021	STAR-Drain MINI, vertical outlet with Ø75 mm outlet, for 65x60	65	63	100	A15	0,090
155-2021	STAR-DRAIN MINI, Closing end cap for 65x100	65	63	20	A15	0,019
156-2021	Star Drain MINI, Open end cap with Ø 40 mm outlet, for 65 x 60	65	63	20	A15	0,024

STAR Drain Mini Stainless Steel Line 65 x 60 mm

ACCESSORIES



**Falcon Line Mini
Corner unit**



**Viking Line Mini
Corner unit**



**Falcon Line Mini
T-unit**



**Viking Line Mini
T-unit**



**Diamond Line Mini
Corner unit**



**Premium Black Line
Mini Corner unit**



**Diamond Line Mini
T-unit**



**Premium Black Line
Mini T-unit**



**Stainless steel Line
Mini Corner unit**



**Stainless steel Line
Mini T-unit**

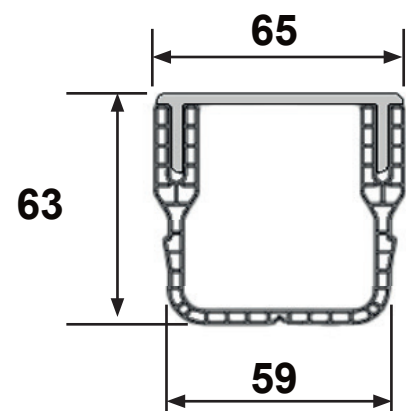

Maximum flow rate : 180 l/min.



Star Drain Mini Stainless Steel

65 x 60 mm

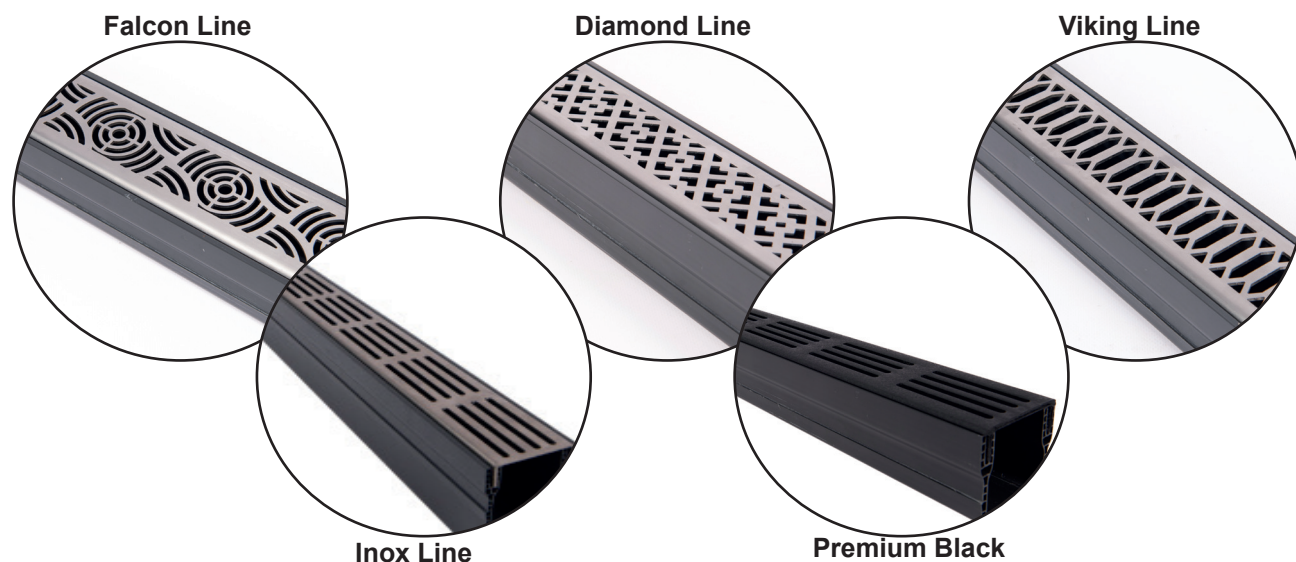

N° art.	Description	Width mm	Height mm	Length mm	Load class	Weight kg
Channel elements (incl. gratings)						
163-2023	Falcon Line-goot MINI 1 m, 65 x 60 mm with grey stainless steel grating	65	63	1000	A15	1,800
164-2023	Viking Line-goot MINI 1 m, 65 x 60 mm with grey stainless steel grating	65	63	1000	A15	1,800
165-2023	Diamond Line-goot MINI 1 m, 65 x 60 mm with grey stainless steel grating	65	63	1000	A15	1,800
166-2023	Premium Black Line-goot MINI 1 m, 65 x 60 mm with black stainless steel grating	65	63	1000	A15	1,334
167-2023	Inox Line-goot MINI 1 m, 65 x 60 mm with grey stainless steel grating	65	63	1000	A15	1,840
Accessories (incl. gratings)						
168-2023	Falcon Line-MINI corner unit with grey stainless steel grating for 65 x 60	65	63	149/149	A15	0,470
169-2023	Viking Line-MINI corner unit with grey stainless steel grating for 65 x 60	65	63	149/149	A15	0,470
170-2023	Diamond Line-MINI corner unit with grey stainless steel grating for 65 x 60	65	63	149/149	A15	0,470
171-2023	Premium Black Line-MINI corner unit with black stainless steel grating for 65 x 60	65	63	149/149	A15	0,350
172-2023	Inox Line-MINI corner unit with grey stainless steel grating for 65 x 60	65	63	149/149	A15	0,470
173-2023	Falcon Line-MINI T-unit with grey stainless steel grating for 65 x 60	65	63	156/182	A15	0,530
174-2023	Viking Line-MINI T-unit with grey stainless steel grating for 65 x 60	65	63	156/182	A15	0,530
175-2023	Diamond Line-MINI T-unit with grey stainless steel grating for 65 x 60	65	63	156/182	A15	0,530
176-2023	Premium Black Line-MINI T-unit with black stainless steel grating for 65 x 60	65	63	156/182	A15	0,400
177-2023	Inox Line-MINI T-unit with grey stainless steel grating for 65 x 60	65	63	156/182	A15	0,530

STAR Drain 65 x 100 mm

ACCESSORIES



Corner unit
aluminium gray



Corner unit
aluminium black



Corner unit
corten steel



Closing end cap



T-unit
aluminium gray



T-unit
aluminium black



T-unit
corten steel



End cap with \varnothing 50 mm
outlet

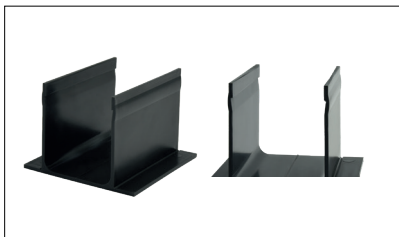

Channel connector

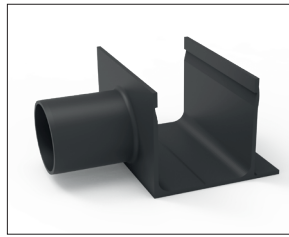

Channel connector
 \varnothing 50 mm with outlet



Channel connector with
 \varnothing 75 mm vertical outlet

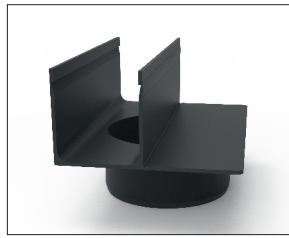

Channel connector with \varnothing 110
mm vertical outlet

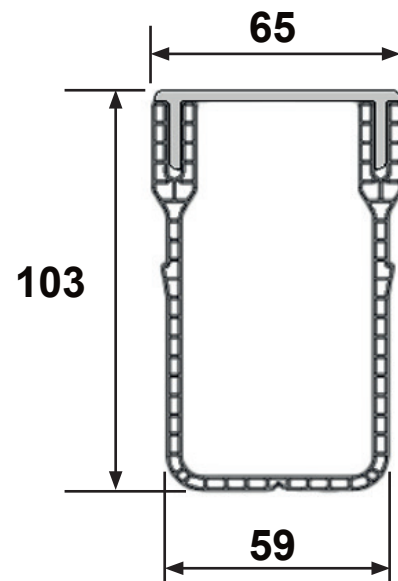

Maximum flow rate: 360 l/min.



STAR Drain

65 x 100 mm

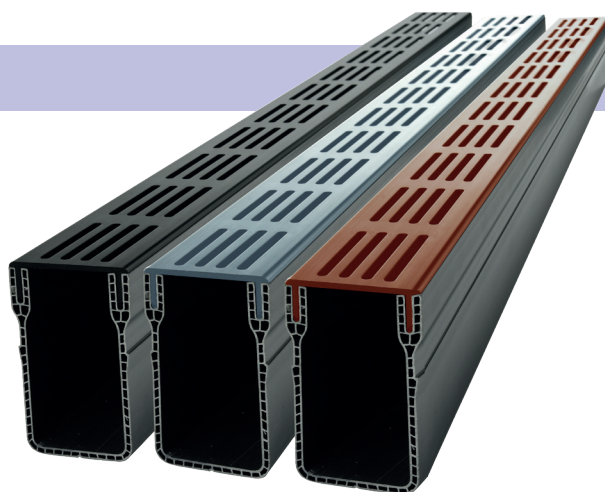

Product line-up

N° art.	Description	Width mm	Height mm	Length mm	Load class	Weight kg
Channel elements (incl. gratings)						
100-2018	STAR Drain-channel 1 m, 65 x 100 mm with gray aluminium grating	65	103	1000	A15	1,750
101-2018	STAR-Drain channel 1m, 65x100 mm. with gray aluminum grating	65	103	2000	A15	3,500
102-2018	STAR-Drain channel 1m, 65x100 mm. with black aluminum grating	65	103	1000	A15	1,750
103-2018	STAR-Drain channel 1m, 65x100 mm. with black aluminum grating	65	103	2000	A15	3,500
104-2018	STAR-Drain channel 1m, 65x100 mm. with corten steel grating	65	103	1000	A15	2,800
Accessories (incl. gratings)						
109-2018	STAR-Drain corner unit with gray aluminum grating for 65x100	65	103	149 / 149	A15	0,625
110-2018	STAR-Drain T-unit with gray aluminum grating for 65x100	65	103	156 / 182	A15	0,700
111-2018	STAR-Drain corner unit with black aluminum grating for 65x100	65	103	149 / 149	A15	0,625
112-2018	STAR-Drain T-unit with black aluminum grating for 65x100	65	103	156 / 182	A15	0,700
113-2018	STAR-Drain corner unit with corten steel grating for 65x100	65	103	149 / 149	A15	0,990
114-2018	STAR-Drain T-unit with corten steel grating for 65x100	65	103	156 / 182	A15	1,280
Accessories (without gratings)						
105-2018	STAR-Drain, channel connector for 65 x 100	65	71	100	A15	0,095
106-2018	STAR-Drain, vertical outlet with Ø75 mm outlet, for 65x100	65	71	100	A15	0,105
107-2018	STAR-Drain, Closing end cap for 65 x 100	65	103	20	A15	0,030
108-2018	STAR-Drain, Open end cap with Ø50 mm outlet, for 65x100	65	103	20	A15	0,030
115-2020	STAR-Drain, channel connector 'one leg' for 65x100	65	103		A15	0,089
116-2020	STAR-Drain, channel connector with vertical outlet 75mm 'single leg' - for 65x100	65	103		A15	0,089
NEW 134-2024	Channel connector Ø50 mm with outlet	65	103		A15	0,110
NEW 135-2024	Channel connector with Ø 110 mm vertical outlet	65	103		A15	0,170

STAR Drain Stainless Steel Line 65 x 100 mm

ACCESSORIES



**Falcon Line
Corner unit**



**Viking Line
Corner unit**



**Falcon Line
T-unit**

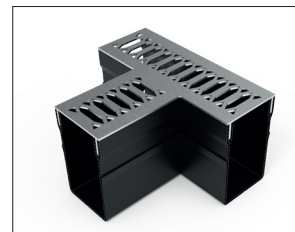

**Viking Line
T-unit**



**Diamond Line
Corner unit**



**Premium Black Line
Corner unit**



**Diamond Line
T-unit**



**Premium Black Line
T-unit**



**Stainless Steel Line
Corner unit**



**Stainless steel Line
T-unit**

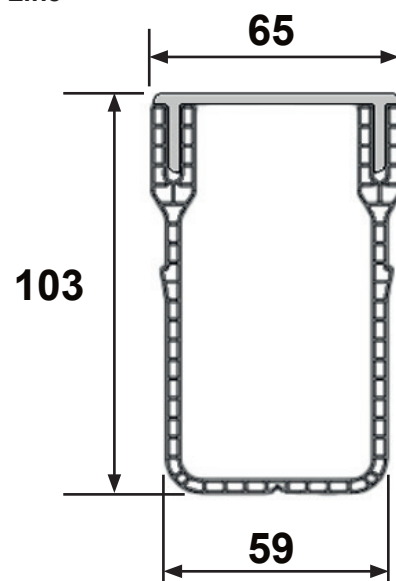

Maximum flow rate : 360 l/min.



Star Drain Stainless Steel

65 x 100 mm

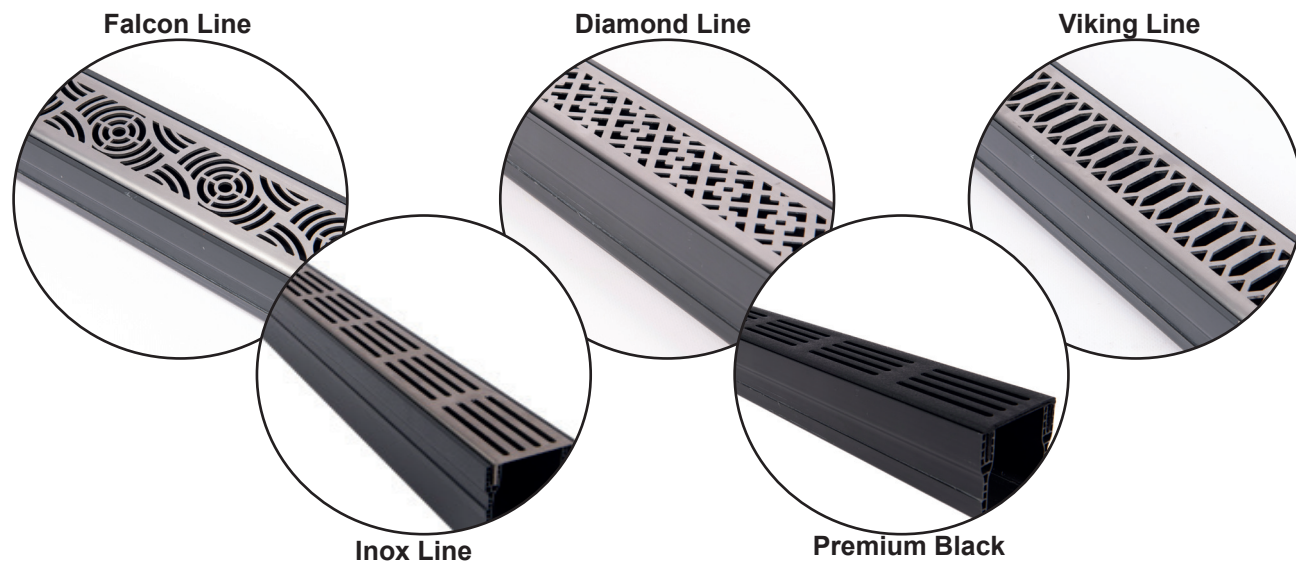

N° art.	Description	Width mm	Height mm	Length mm	Load class	Weight kg
Channel elements (incl. gratings)						
117-2023	Falcon Line-goot 1 m, 65 x 100 mm with grey stainless steel grating	65	103	1000	A15	2,230
118-2023	Viking Line-goot 1 m, 65 x 100mm with grey stainless steel grating	65	103	1000	A15	2,230
119-2023	Diamond Line-goot 1 m, 65 x 100 mm with grey stainless steel grating	65	103	1000	A15	2,230
120-2023	Premium Black Line-goot 1 m, 65 x 100 mm with black stainless steel grating	65	103	1000	A15	1,740
121-2023	Inox Line-goot 1 m, 65 x 100mm with grey stainless steel grating	65	103	1000	A15	2,245
Accessories (incl. gratings)						
122-2023	Falcon Line-corner unit with grey stainless steel grating for 65 x 100	65	103	149/149	A15	0,580
123-2023	Viking Line-corner unit with grey stainless steel grating for 65 x 100	65	103	149/149	A15	0,580
124-2023	Diamond Line-corner unit with grey stainless steel grating for 65 x 100	65	103	149/149	A15	0,580
125-2023	Premium Black Line-corner unit with black stainless steel grating for 65 x 100	65	103	149/149	A15	0,455
126-2023	Inox Line-corner unit with grey stainless steel grating for 65 x 100	65	103	149/149	A15	0,570
127-2023	Falcon Line-T-unit with grey stainless steel grating for 65 x 100	65	103	156/182	A15	0,690
128-2023	Viking Line-T-unit with grey stainless steel grating for 65 x 100	65	103	156/182	A15	0,690
129-2023	Diamond Line-T-unit with grey stainless steel grating for 65 x 100	65	103	156/182	A15	0,690
130-2023	Premium Black Line-T-unit with black stainless steel grating for 65 x 100	65	103	156/182	A15	0,510
131-2023	Inox Line- T-unit with grey stainless steel grating for 65 x 100	65	103	156/182	A15	0,650

AQUA Drain 100 x 100 mm

ACCESSORIES



Corner unit
aluminium gray



Corner unit
aluminium black



Corner unit stainless
steel



Connection part



T- unit
aluminium gray



T- unit
aluminium black



T- unit stainless steel



Connection part with
Ø 110 mm outlet



Closing end cap

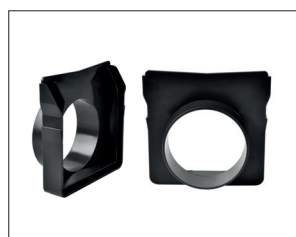

Closing end cap with
Ø75 mm outlet



100 x 100 mm
elements are
acesable with drain
holes in one side,
two sides or in
bottom of
the channel body.

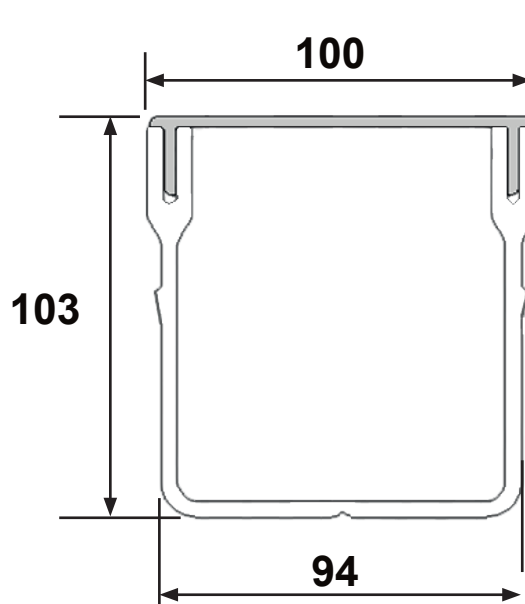

Maximum flow rate : 400 l/min.



AQUA Drain

100 x 100 mm

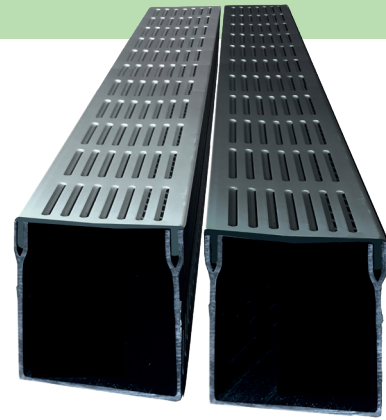

Product line-up

N° art.	Description	Width mm	Height mm	Length mm	Load class	Weight kg
Channel elements (incl. gratings)						
300-2020	STAR-Drain channel 1m, 100x100 mm. with gray aluminum grating	100	103	1000	A15	2,900
301-2020	STAR-Drain channel 2m, 100x100 mm. with gray aluminum grating	100	103	2000	A15	5,800
305-2020	STAR-Drain channel 1m, 100x100 mm. with black aluminum grating	100	103	1000	A15	2,900
306-2020	STAR-Drain channel 2m, 100x100 mm. with black aluminum grating	100	103	2000	A15	5,800
302-2020	STAR-Drain channel 1m, 100x100 mm. with gray aluminum grating, drain holes on 1 side	100	103	1000	A15	2,850
307-2020	STAR-Drain channel 1m, 100x100 mm. with black aluminum grating, drain holes on 1 side	100	103	1000	A15	2,850
303-2020	STAR-Drain channel 1m, 100x100 mm. with gray aluminum grating, drain holes on 2 sides	100	103	1000	A15	2,800
308-2020	STAR-Drain channel 1m, 100x100 mm. with black aluminum grating, drain holes on 2 sides	100	103	1000	A15	2,800
304-2020	STAR-Drain channel 1m, 100x100 mm. with gray aluminum grating, drain holes in bottom	100	103	1000	A15	2,850
309-2020	STAR-Drain channel 1m, 100x100 mm. with black aluminum grating, drain holes in bottom	100	103	1000	A15	2,850
318-2023	STAR-Drain channel 1m, 100x100 mm. with grey stainless steel grating	100	103	1000	A15	4,080
Accessories (incl. gratings)						
314-2020	STAR-Drain corner unit with gray aluminum grating for 100x100	100	103	197 / 197	A15	0,650
315-2020	STAR-Drain T-unit with gray aluminum grating for 100x100	100	103	196 / 272	A15	0,795
316-2020	STAR-Drain corner unit with black aluminum grating for 100x100	100	103	197 / 197	A15	0,650
317-2020	STAR-Drain T-unit with black aluminum grating for 100x100	100	103	196 / 272	A15	0,795
319-2023	STAR-Drain corner unit with grey stainless steel grating for 100x100	100	103	197/197	A15	1,040
320-2023	STAR-Drain T-unit with grey stainless steel grating for 100x100	100	103	196/272	A15	1,240
Accessories (without gratings)						
310-2020	Star Drain, Channel connector for 100 x 100	100	71	135	A15	0,160
311-2020	STAR-Drain, vertical outlet with Ø110 mm outlet, for 100x100	100	71	135	A15	0,165
312-2020	Star Drain, Closing end cap for 100 x 100	100	103	20	A15	0,065
313-2020	STAR-Drain, Open end cap with Ø75 mm outlet, for 100x100	100	103	20	A15	0,072

ACCESSORIES



Corner unit
aluminium gray



Corner unit
aluminium black



Corner unit stainless
steel



Closed end cap
steel



T- unit
aluminium gray



T- unit
aluminium black



T- unit stainless
steel

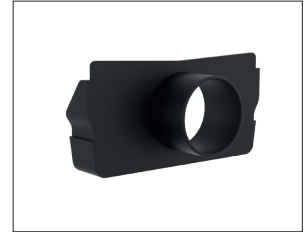

Closed end cap with
Ø 30mm outlet



Channel connector

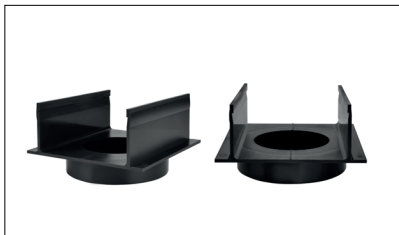

Channel connector with
Ø 110 mm vertical outlet

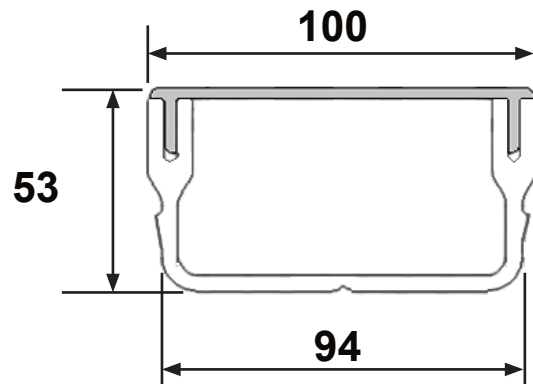

Maximum flow rate : 330 l/min.



AQUA Drain

100 x 50 mm



Product line-up

N° art.	Description	Width mm	Height mm	Length mm	Load class	Weight kg
Channel Elements (incl. gratings)						
200-2020	STAR-Drain channel 1m, 100x50 mm. with gray aluminum grating	100	53	1000	A15	2,460
201-2020	STAR-Drain channel 2m, 100x50 mm. with gray aluminum grating	100	53	2000	A15	4,920
202-2020	STAR-Drain channel 1m, 100x50 mm. with black aluminum grating	100	53	1000	A15	2,460
203-2020	STAR-Drain channel 2m, 100x50 mm. with black aluminum grating	100	53	2000	A15	4,920
213-2020	STAR-Drain channel 1m, 100x50 mm. with stainless steel grating	100	53	1000	A15	3,620
Accessories (incl. gratings)						
208-2020	STAR-Drain corner unit with gray aluminum grating for 100x50	100	53	197 / 197	A15	0,580
210-2020	STAR-Drain T-unit with gray aluminum grating for 100x50	100	53	196 / 272	A15	0,725
209-2020	STAR-Drain corner unit with black aluminum grating for 100x50	100	53	197 / 197	A15	0,580
211-2020	STAR-Drain T-unit with black aluminum grating for 100x50	100	53	196 / 272	A15	0,725
214-2020	STAR-Drain corner unit with stainless steel grating for 100x50	100	53	197 / 197	A15	0,900
215-2020	STAR-Drain T-unit with stainless steel grating for 100x50	100	53	196 / 272	A15	1,200
Accessories (without gratings)						
204-2020	Star Drain, Channel connector for 100 x 50	100	21	135	A15	0,105
205-2020	STAR-Drain, vertical outlet with Ø110 outlet, for 100 x 50	100	21	135	A15	0,125
206-2020	Star Drain, Closing end cap for 100 x 50	100	53	20	A15	0,037
207-2020	STAR-Drain, Open end cap with Ø30 outlet, for 100 x 50	100	53	20	A15	0,045

Top - Stone 100 x 100 mm

ACCESSOIRES

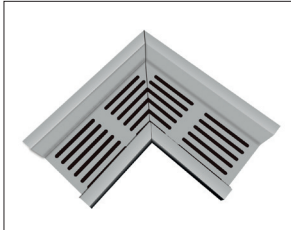

Corner unit
aluminium grey

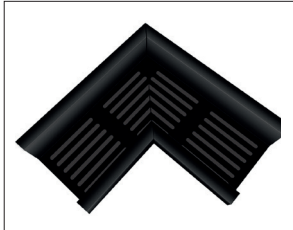

Corner unit
aluminium black

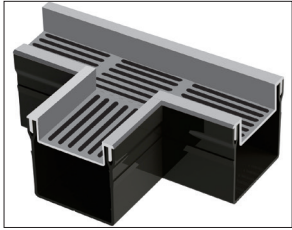

T- unit
aluminium grey

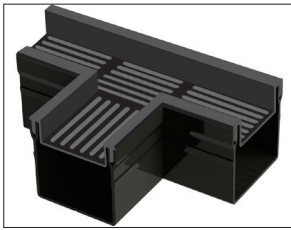

T- unit
aluminium black

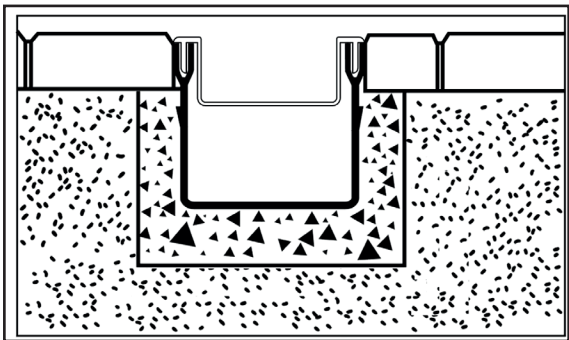

Maximum flow rate : 400 l/min.



TOP Stone

100 x 100 mm



Product line-up

N° art.	Description	Width mm	Height mm	Length mm	Load Class	Weight kg
Channel Elements (incl. gratings)						
900-2022	Channel Top Stone 1 m, 100 x 100 mm with gray aluminum grating	100	50	1000	A15	2,912
901-2022	Channel Top Stone 1 m, 100 x 100 mm with black aluminum grating	100	50	1000	A15	2,912
Accessories (incl. gratings)						
902-2022	Top Stone corner unit with gray aluminum grating for 100 x 100	100	50	197/197	A15	0,700
904-2022	Top Stone T-unit with gray aluminum grating for 100 x 100	100	50	196/272	A15	0,900
903-2022	Top Stone corner unit with black aluminum grating for 100 x 100	100	50	197/197	A15	0,700
905-2022	Top Stone T-unit with black aluminum grating for 100 x 100	100	50	196/272	A15	0,900
Accessories (without gratings)						
310-2022	Star Drain, Channel connector for 100 x 100	100	71	135	A15	0,160
311-2022	STAR-Drain, vertical outlet with Ø110 outlet, for 100 x 100	100	71	135	A15	0,165
312-2022	Star Drain, Closing end cap for 100 x 100	100	100	20	A15	0,065
313-2022	STAR-Drain, Open end cap with Ø75 outlet, for 100 x 100	100	100	20	A15	0,072

STAR Point

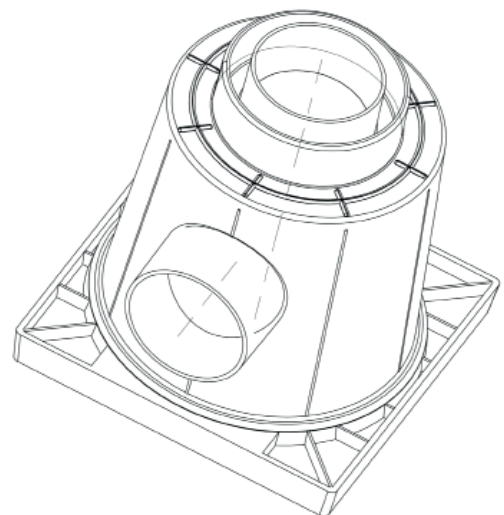
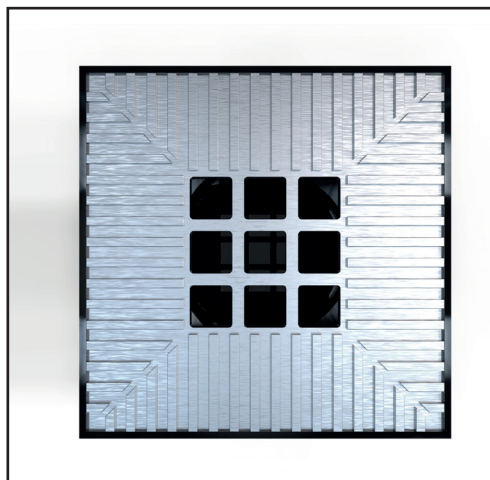

STAR Point

200 x 200 mm



Product Line-up

N° art.	Description	Width mm	Height mm	Length mm	Load Class	Weight kg
Channel elements (incl gratings)						
800-2022	Star Point- 200 x 200 mm with outlet 75mm - bottom outlet 75/110mm with closing cap - Grey	20	21	20	A15	1,500
801-2022	Star Point- 200 x 200 mm with outlet 75mm - bottom outlet 75/110mm with closing cap - Black	20	21	20	A15	1,500

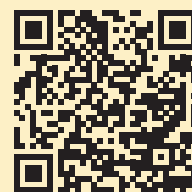

NEW !

STAR Point Stone

200 x 200 mm

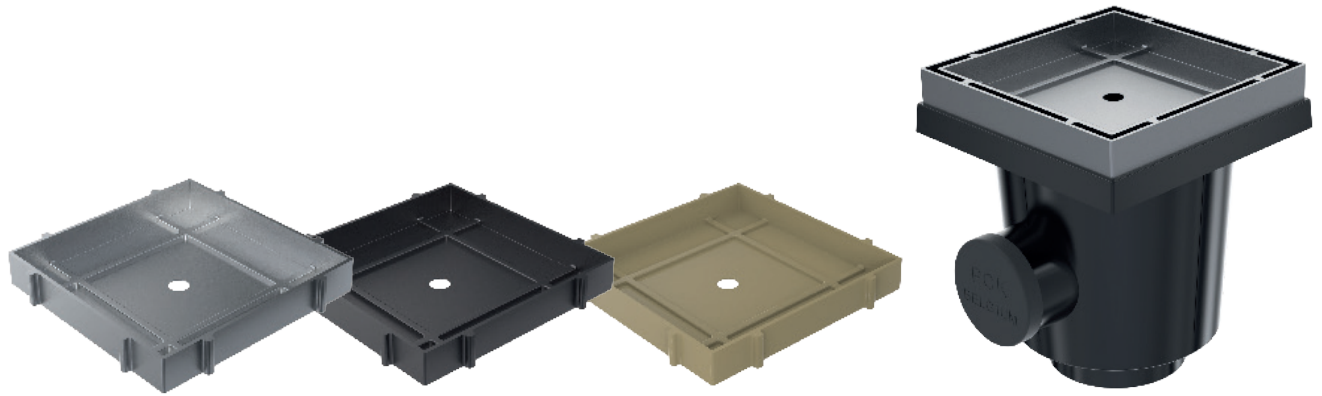

Product Line-Up

N° art.	Description	Width mm	Height mm	Length mm	Load Class	Weight kg
Channel elements (with gratings)						
803-2025	Star Point Stone- 200 x 200 mm with outlet 75mm - bottom outlet 75/110mm with closing cap - Grey	20	21	20	A15	1,630
804-2025	Star Point Stone - 200 x 200 mm with outlet 75mm - bottom outlet 75/110mm with closing cap - Black	20	21	20	A15	1,630
805-2025	Star Point Point- 200 x 200 mm with outlet 75mm - bottom outlet 75/110mm with closing cap - Sand Yellow	20	21	20	A15	1,630

ACCESSORIES



Standard inspection cover



Inspection cover with horizontal drain



Inspection cover with vertical drain

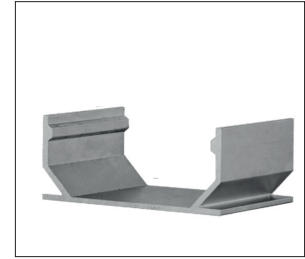

Connector



Closed end piece right

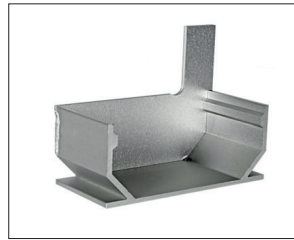

Closed end piece left

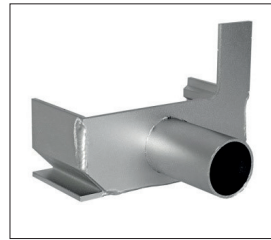

End piece with horizontal drain - right

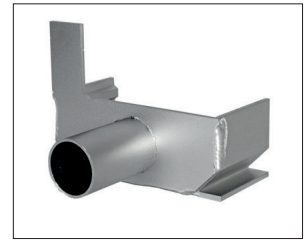

End piece with horizontal drain - left

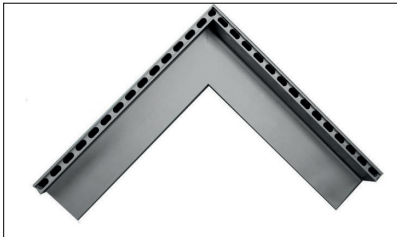

External corner connection 500/500

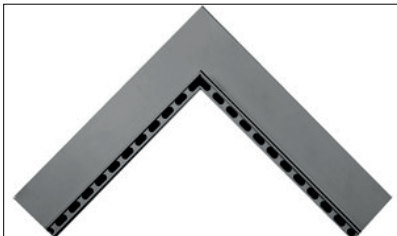

Internal corner connection 500/500

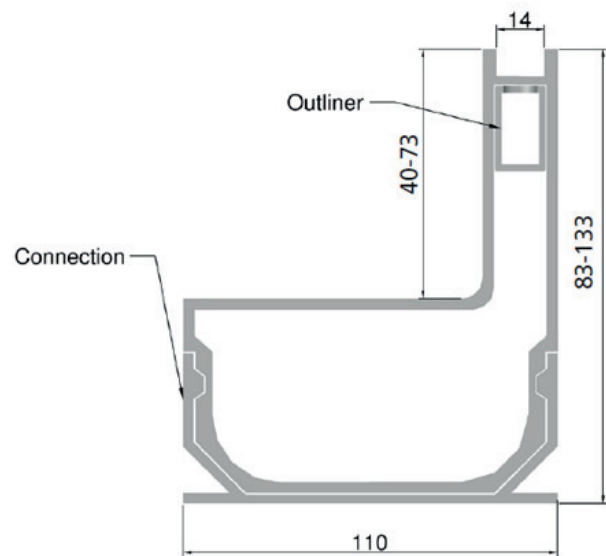

Maximum flow rate : 75kn.

Side Drain 40

110 x 83 mm



Product line-up

N° art.	Description	Width mm	Height mm	Length mm	Load class	Weight kg
Channel elements						
1000-2012	Side Drain 40, 500mm 110 x 40 mm - grey	110	83	500	B125	1,550
1001-2012	Side Drain 40, 1000mm 110 x 40 mm - grey	110	83	1000	B125	3,100
Accessories						
1003-2012	Side Drain 40 Alu connector - grey	110	n/A	70	B125	0,120
1004-2012	Side Drain 40 Alu standard inspection cover 250mm - grey	110	n/A	2000	B125	1,920
1005-2012	Side Drain 40 Alu inspection cover 250mm with horizontal drain dia 30 - grey	110	n/A	260	B125	1,920
1006-2012	Side Drain 40 Alu inspection cover 250mm with vertical drain dia 75 - grey	110	n/A	520	B125	1,920
1007-2012	Side Drain 40 Alu closed end piece right - grey	n/A	n/A	50	B125	0,150
1008-2012	Side Drain 40 Alu closed end piece left - grey	n/A	n/A	50	B125	0,150
1009-2012	Side Drain 40 Alu end piece with horizontal drain dia 30 - right - grey	n/A	n/A	50	B125	0,150
1010-2012	Side Drain 40 Alu end piece with horizontal drain dia 30 - left - grey	n/A	n/A	50	B125	0,150
1011-2012	Side-Drain 40 Alu external corner connection 500/500 - grey	110	n/A	500/500	B125	4,120
1012-2012	Side-Drain 40 Alu internal corner connection 500/500 - grey	110	n/A	500/500	B125	4,120

ACCESSORIES



Standard inspection cover



Inspection cover with horizontal drain



Inspection cover with vertical drain

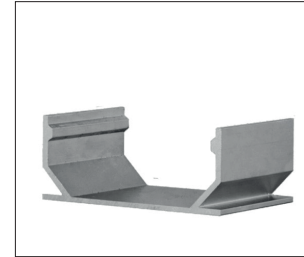

Connector



Closed end piece right



Closed end piece left

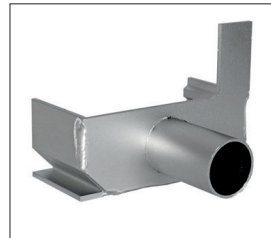

End piece with horizontal drain - right

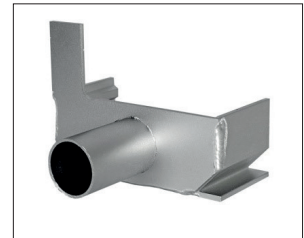

End piece with horizontal drain - left

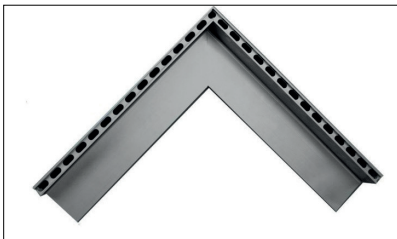

External corner connection 500/500

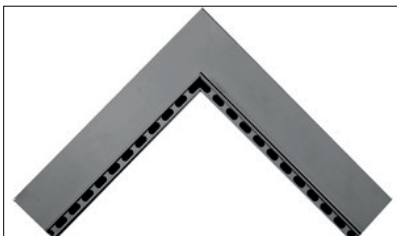

Internal corner connection 500/500

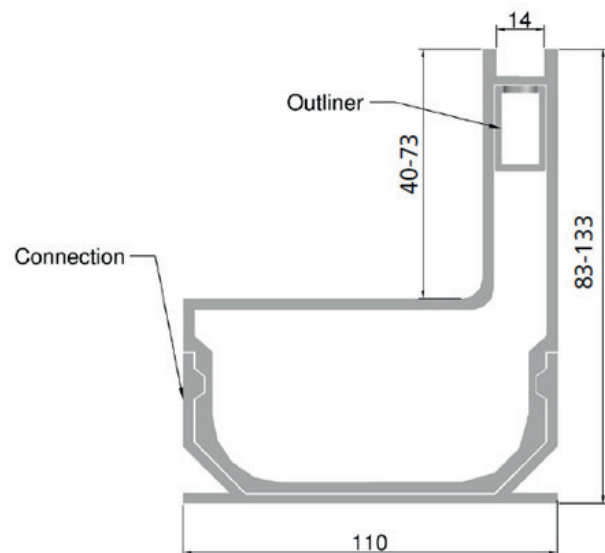

Maximum flow rate : 75kn.

Side Drain 75

110 x 75 mm

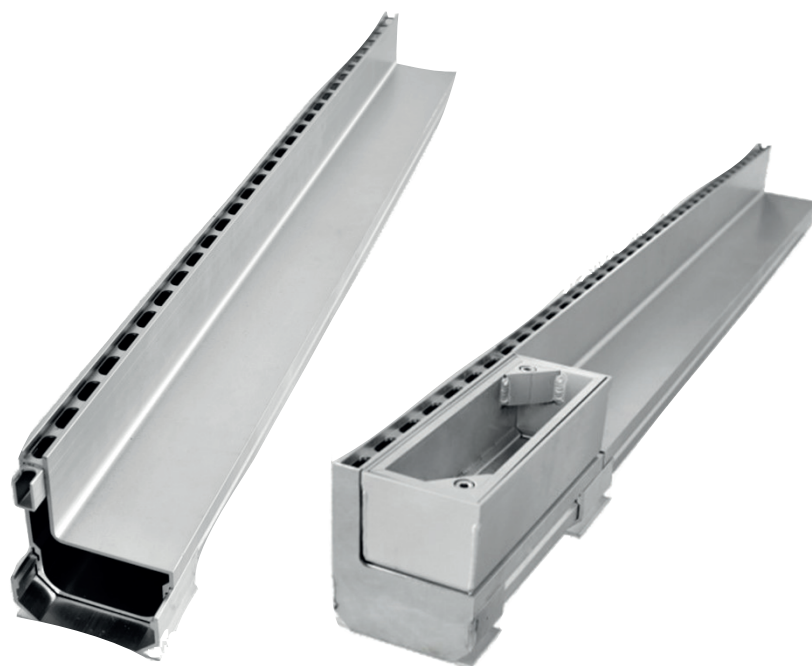

Product line-up

N° art.	Description	Width mm	Height mm	Length mm	Load class	Weight kg
Channel elements						
1100-2012	Side Drain 75, 500mm 110 x 75 mm - grey	110	133	500	B125	2,060
1101-2012	Side Drain 75, 1000mm 110 x 75 mm - grey	110	133	1000	B125	4,120
Toebehoren						
1103-2012	Side Drain 75 Alu connector - grey	110	n/A	70	B125	0,120
1104-2012	Side Drain 75 Alu standard inspection cover 250mm - grey	110	n/A	2000	B125	1,920
1105-2012	Side Drain 75 Alu inspection cover 250mm with horizontal drain dia 50 - grey	110	n/A	260	B125	1,920
1106-2012	Side Drain 75 Alu inspection cover 250mm with vertical drain dia 75 - grijs	110	n/A	520	B125	1,920
1107-2012	Side Drain 75 Alu closed end piece right - grey	n/A	n/A	50	B125	0,150
1108-2012	Side Drain 75 Alu closed end piece left - grey	n/A	n/A	50	B125	0,150
1109-2012	Side Drain 75 Alu closed end piece with horizontal drain dia 50 - right - grey	n/A	n/A	50	B125	0,150
1110-2012	Side Drain 75 Alu closed end piece with horizontal drain dia 50 - left - grey	n/A	n/A	50	B125	0,150
1111-2012	Side-Drain 75 Alu External corner connection 500/500 - grey	110	n/A	500/500	B125	4,120
1112-2012	Side-Drain 75 Alu Internal corner connection 500/500 - grey	110	n/A	500/500	B125	4,120

ACCESSORIES



X - Line
Corner Grey



X - Line
Corner Black

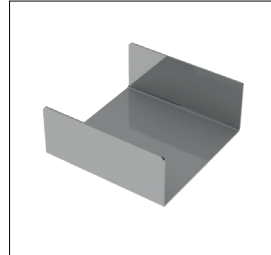

X - Line
Connection part Grey



X - Line
Connection part Black

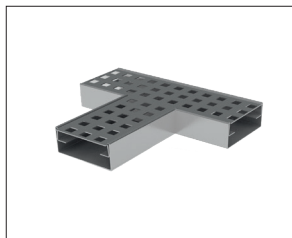

X - Line
T-unit grey



X - Line
T-unit black

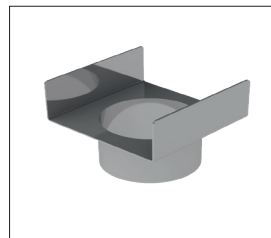

X - Line
Channel connector
with Ø 50 mm vertical
outlet grey

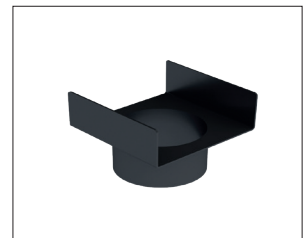

X - Line
Channel connector with
Ø 50 mm vertical outlet
black

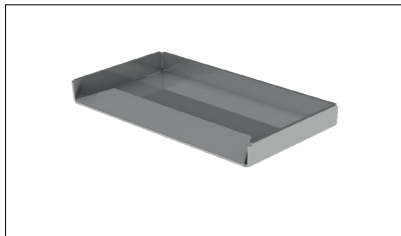

X - Line
End cap - grey



X - Line
End cap - black

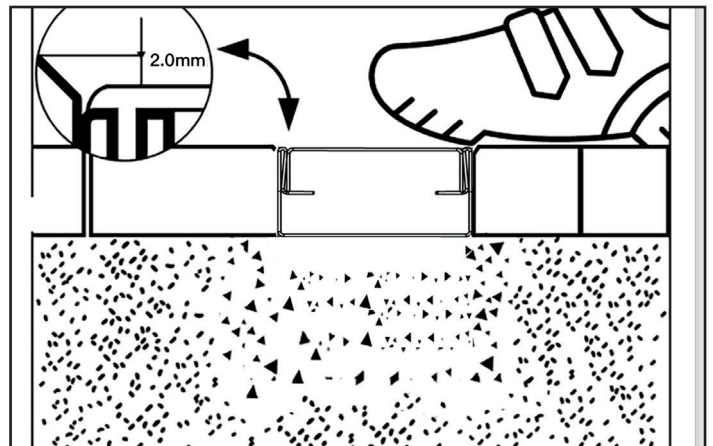

Maximale debiet : 180l/min

NEW !

X - Line Stainless steel

65 x 35 mm



Product Line - Up

N° art.	Description	Width mm	Height mm	Length mm	Load Class	Weight kg
Channel elements						
500-2024	X-Line channel 500mm, 65 x 35 mm with stainless steel grating - Grey	65	35	500	A15	0,930
501-2024	X-Line channel 1m, 65 x 35 mm with stainless steel grating - Grey	65	35	1000	A15	1,860
502-2024	X-Line channel 1m, 65 x 35 mm with stainless steel grating and vertical outlet 50mm- grey	65	35	1000	A15	1,890
550-2024	X-Line channel 500mm, 65 x 35 mm with stainless steel grating - Black	65	35	500	A15	0,930
551-2024	X-Line channel 1m, 65 x 35 mm with stainless steel grating - Black	65	35	1000	A15	1,860
552-2024	X-Line channel 1m, 65 x 35 mm with stainless steel grating and vertical outlet 50mm- Black	65	35	1000	A15	1,890
Accessories						
503-2024	X-Line, corner unit with grey stainless steel grating for 65 x 35	65	n/A	150/150	A15	0,450
504-2024	X-Line, T-unit with grey stainless steel grating voor 65 x 35	65	n/A	160/183	A15	0,490
553-2024	X-Line, corner unit with black stainless steel grating for 65 x 35	65	n/A	150/150	A15	0,450
554-2024	X-Line, T-unit with black stainless steel grating for 65 x 35	65	n/A	160/183	A15	0,490
505-2024	X-Line, Connection part grey for 65 x 35	65	n/A	65	A15	0,080
506-2024	X-Line, Connection part grey vertical outlet with Ø 50 mm, for 65 x 35	65	n/A	65	A15	0,054
507-2024	X-Line, End cap grey for 65 x 35	65	n/A	15	A15	0,030
555-2024	X-Line, Connection part black for 65 x 35	65	n/A	65	A15	0,080
556-2024	X-Line, Connection part black vertical outlet with Ø 50 mm, for 65 x 35	65	n/A	65	A15	0,054
557-2024	X-Line, End cap black for 65 x 35	65	n/A	15	A15	0,030

Supplies

Supplies for our range



Clock Drill 45mm



Clock Drill 75mm

Inspection Rubber

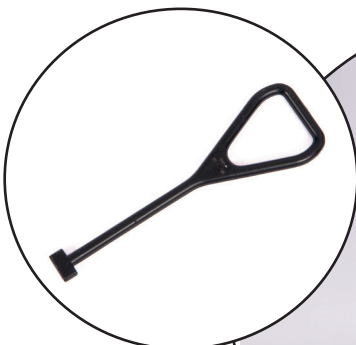

Lifting Tool

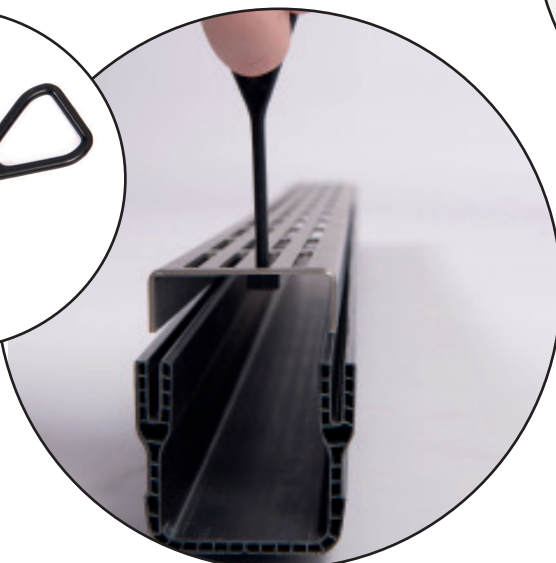

SUPPLIES

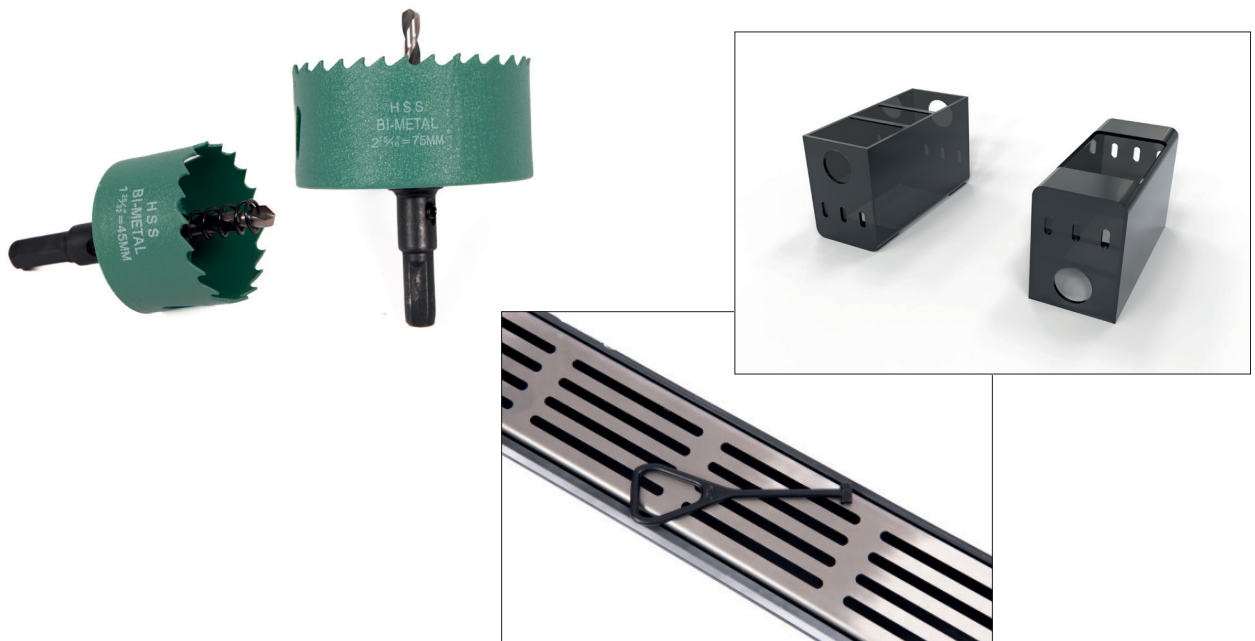

Product Line-up

N° art.	Description	Width mm	Height mm	Length mm	Load class	Weight kg
Clock Drill						
1000-2023	Clock Drill of diameter 45mm, for Star Drain 65/100 & Mini 65/60	45		85	n/a	0,120
1001-2023	Clock Drill of diameter 75mm, for Aqua Drain 100/100 & 50/100	75		95	n/a	0,304
Lifting tool & Inspection rubber						
1002-2023	Liftingtool for drainage gratings Star Drain, Mini Drain en Aqua Drain				n/a	0,010
1003-2023	Inspection rubber Star Drain 65/100	45	65	108	n/a	0,050

Displays

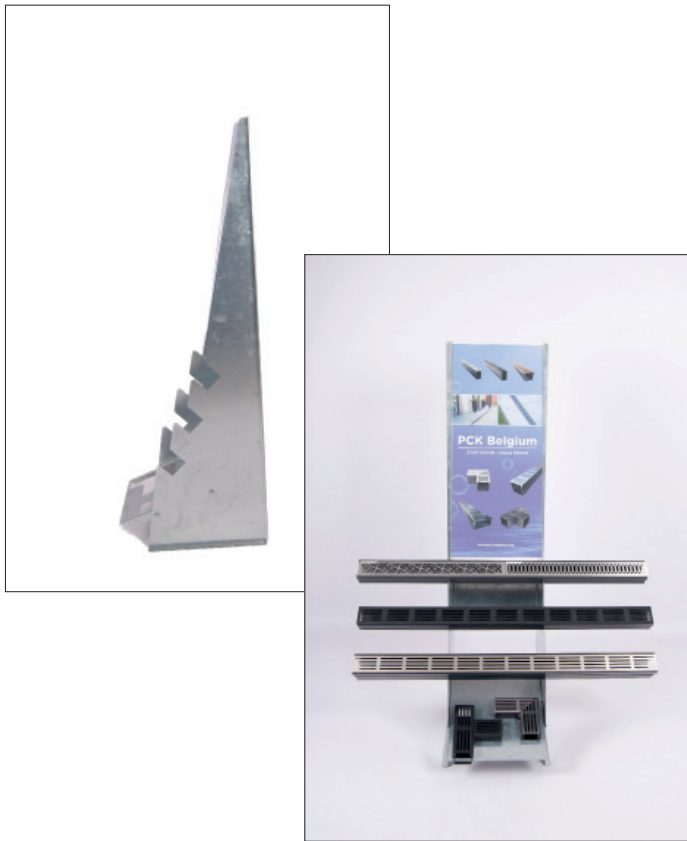

Display Galvanised

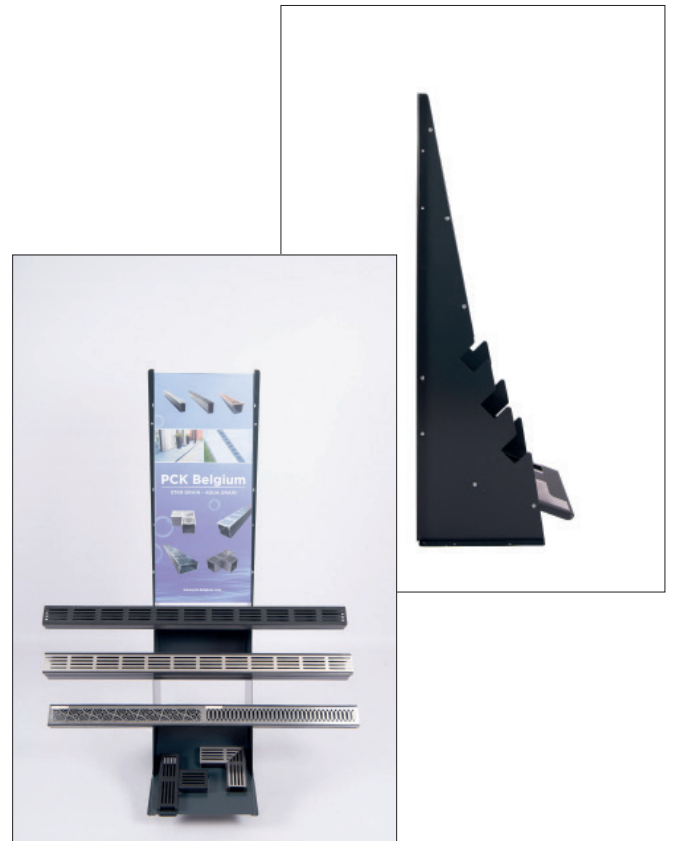

Display Anthracite/Gray

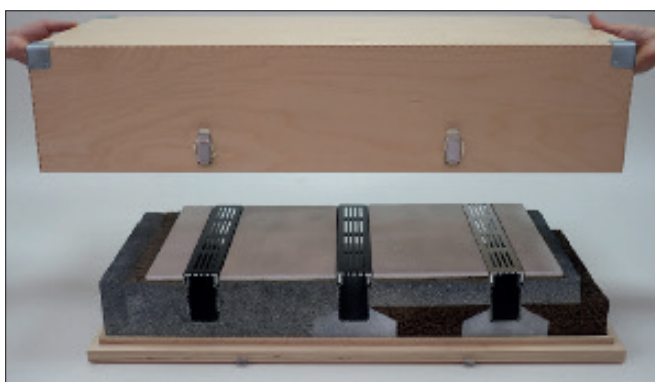

3D Box Star Drain



3D Box Alu Side Drain - Inspection cover

DISPLAYS

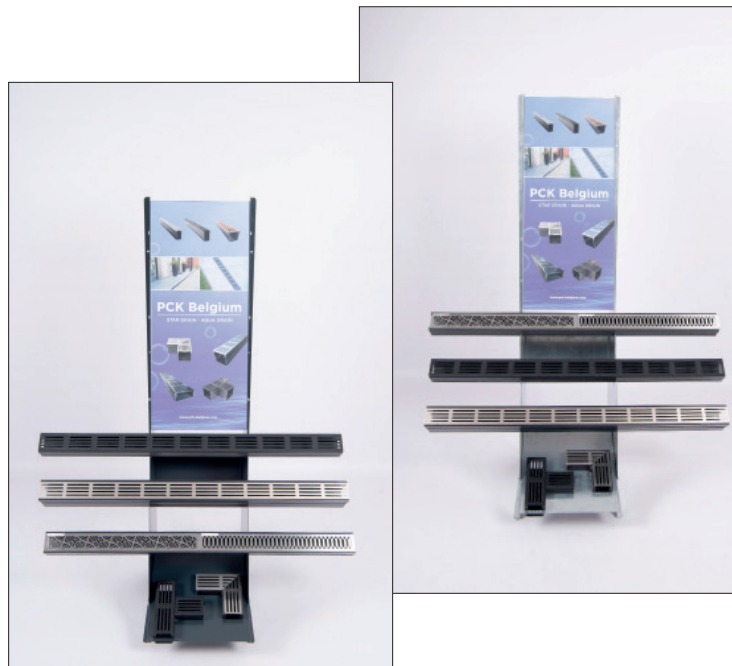

Product Line-up

N° art.	Description	Width mm	Height mm	Length mm	Load class	Weight kg
Displays						
1004-2023	Display galvanised natural for Star Drain 65/100 and Mini 65/60	370	1400	500	N.V.T.	15 kg
1005-2023	Display anthracite / gray for Star Drain 65/100 and Mini 65/60	370	1400	500	N.V.T.	15 kg
3D Box						
1006-2023	3D Box of Star Drain 65/100	1000	350	550	N.V.T.	20 kg
1007-2023	3D Box of Alu Side drain and inspection cover	1000	350	550	N.V.T.	20 kg

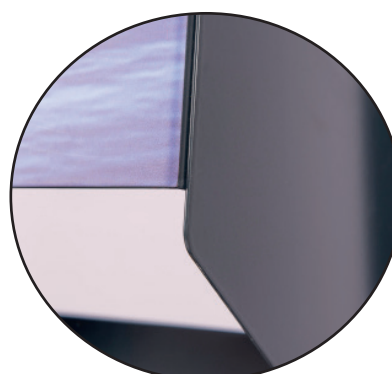

Personalized sticker on request!

Stainless Steel range

What is stainless steel ?

Stainless steel is known for its versatile and wear-resistant material. It can be used both indoors and outdoors. In fact, stainless steel is not completely free of rust. There is even a layer of rust on the metal, called the oxide layer. This thin oxide layer is clear in color and not visible. This is in contrast to rust on normal steel, which is easy to see and leaves brown stains on the material. The oxide layer on stainless steel is present on the entire surface and acts as a kind of protective layer. It stops the oxidation process and thus actually prevents "rusting".

This protects the metal from external influences.

PCK Belgium has something for everyone by designing different designs. Also available in different sizes

Specification stainless steel grating thickness 2mm,
1.4301 AND ISO 9445/10088-2

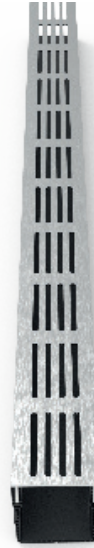

Stainless Steel - Designs

Falcon Line

The rounded part of the design offers a nice contrast to any environment



Viking Line

To find the name of this design, of course, this was easy. With the viking boats outlined on the design, we came immediately to the conclusion with "Viking".



Diamond Line

Diamonds are always the perfect image to have as a design. Sleek but also very pleasant to look at.



CORTEN STEEL

What is corten steel ?

Corten steel has in recent years become more and more popular in many architectural outdoor projects due to the natural oxidizing finish, which creates a very special and unique look and minimizes the need for maintenance.

Corten is a special steel alloy, developed to avoid the need for painting and maintenance. When corten steel is exposed to weather and wind, in time the surface acquires a stable and rust-like patina, which increases the steel's resistance to atmospheric corrosion compared to other types of steel.

Corten steel resists corrosive effects of rain, snow, ice, fog and other meteorological conditions by forming a coating of dark brown oxidation over the metal, which prevents deeper penetration and removes the need for paint and rust prevention maintenance.

In short, the steel is allowed to rust on the surface, thereby forming a protective coating that reduces the rate of future corrosion.



When you purchase Star - Drain with gratings in corten steel

When you purchase STAR-Drain with grates of corten steel, the patina may not have had the time to fully develop, at the time of delivery. The grating may look something like in the picture below.

During the patination process, rain water may get a rusty brown color and leave stains and discoloration to the surrounding (porous) surfaces.

We recommend separated storage of the gratings, in a place where the patina can fully develop, until they look like in below picture. Depending on the time of year, this takes just a few weeks of exposure to moisture and fresh air

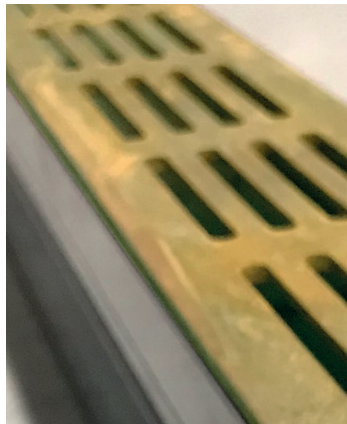
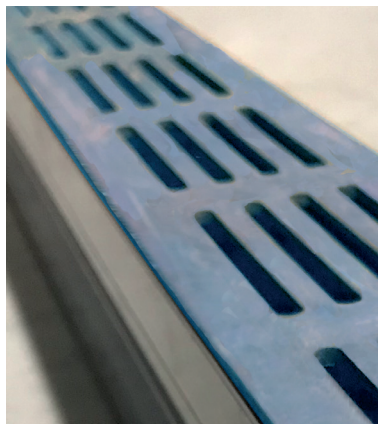

INSTALLATION INSTRUCTIONS

STAR-Drain is a drainage channel system that consists of a plastic (PVC) channel element with an aluminum or corten steel grating. The drainage channel is for use around the home, in areas with no traffic or light traffic only (pedestrians, trollies, cyclists, etc.).

1. With STAR-Drain, the water from the channel can be discharged to either the sewer or an infiltration system (LAR) through optionally a side or a vertical bottom outlet. By directing the water to an infiltration system (LAR), you work sustainably to improve the soil's water balance
2. To make a horizontal end outlet, use the open end cap with integrated outlet connection. Ø30 mm, Ø50 mm or Ø75 mm depending on channel model. For a vertical bottom outlet, use the vertical outlet connection (find both connection units available in accessories). For vertical bottom outlet first drill a hole of 45-50 mm (or 90-95 mm depending on channel model) in the bottom of the channel using a hole saw, exactly next to the location of the drain. Then glue and mount the bottom outlet connection unit to the bottom side of the channel

Attention:

1. Connect a suitable number of drain outlets per channel string depending on the inflow area. You can prevent odors by installing a siphon when connecting to the waste water sewer.
2. Make a trench of approx. 15 cm deep for the foundation. The foundation must have minimum dimensions: 5 cm high and 10 cm wide.
3. Apply stabilized sand in the trench in the ratio 1 : 3 (cement : sand). Adjust the mixture to the desired height. Click the connecting pieces around the channel elements and adjust to the correct height. Fill the trench to the bottom of the pavement with sand cement.

NB! - Always leave the grate in the channel element during installation, to avoid any deformation of the channel

4. **Carefully compact the foundation strip around the channel, leaving the channel in its original form.**

TIP: ✓ With new paving, we advise you to tension a wire to determine the height level
Always set the grate 4mm below the wire.

- ✓ If you install the channel in existing paving, we advise you to make a wooden template with the desired height, which you can strike off
- ✓ When the channel is laid along an upright wall, the flaps of the connecting piece must be cut off on that side.

5. You have the option of shortening both the channel element and the grate to any desired length using a hacksaw or an angle grinder
6. The end are attached to channel ends. due to the difference in the expansion coefficient of plastic (channel) and aluminium and corten steel (grates) a small deviation in length may possibly occur over time between the channels and the grates
7. All plastic parts can be connected to each other in waterproof joints using PVC glue



FAQ

Is the Star-Drain or Aqua Drain grid subject to oxidation ?

No, because the aluminium grid is anodised in accordance with maritime quality specifications.

Can we drive over the Star-Drain and Aqua Drain with a vehicle?

Yes, with a maximum speed of 30km/h and provided that the drainage has been installed in accordance with the installation instructions.

Where and for which application can I use the drainage exactly?

In the area where the Star Drain and Aqua Drain must be installed. Consult the architect, contractor or specialised construction material trader where you want to install the drainage. Obviously, if there is much precipitation in an area, a wider drain must be installed, such as the Aqua Drain, and in drier areas, a narrower drain, such as the Star Drain.

Which is the maximum flow rate of the Star-Drain and the Aqua Drain?

- Star Drain 65/100 - 360 l/m.
- Aqua Drain 50/100 - 330 l/m.
- Aqua Drain 100/100 - 400 l/m.

Can the plastic channel and the aluminium grid be shortened?

Yes, they can be shortened by using the appropriate tools. Ensure that any sharp edges are removed after shortening both in relation to the PVC channel and the aluminium grid.

Can the line drain be installed on a balcony or terrace?

Yes, the Aqua Drain 50/100 has been especially designed for this application. Due to its height of 50 mm, this is the right drain for this.

Can the line drain be recycled?

Yes, all products designed by PCK Belgium can be fully recycled. Both the plastic channel and the aluminium grid can therefore be recycled.



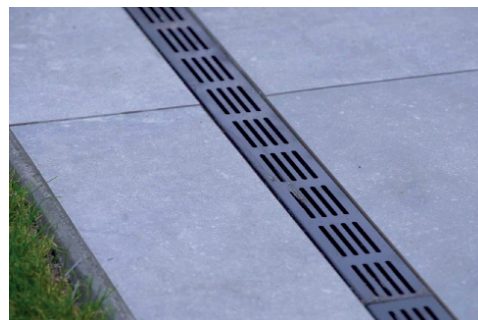

© Copyright 2025 - PCK Belgium - We aanvaarden geen aansprakelijkheid voor eventuele drukfouten. De kleuren in de brochure zijn gedrukte kleuren en kunnen afwijken van de geleverde producten.

*Please find more info www.pck-belgium.com
Recently you can order online*



Rue de L'industrie 28
6940 Barvaux



0032 479 49 88 31



www.pck-belgium.com